

HEEL SHROUDS

PROTECTION AGAINST CHEEK AND FLOOR DAMAGE



Benefits:

- Decreased associated down time of the bucket
- Prolonged Bucket service life.
- Reduced maintenance costs

Use: Heel Shrouds minimise the exposure of both the bottom of the bucket shell and the critical weld area between the bucket floor and side wall to wear during the loading cycle.

EC3515S & EC2800SS

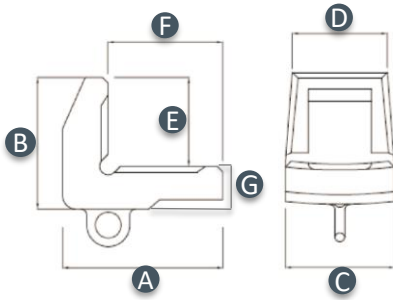

EC2870SS

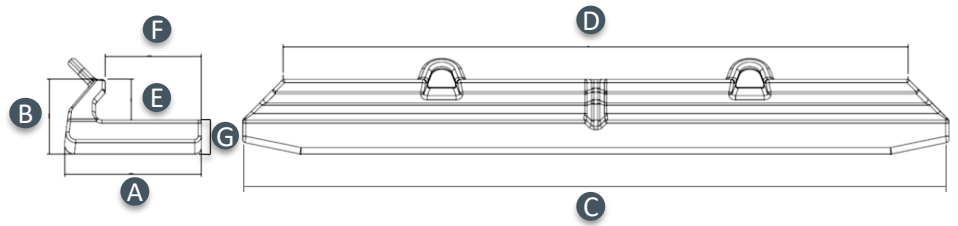

Product Code	Description	Weight	A	B	C	D	E	F	G
EC3515S	Heel Shroud	24kg	260mm	150mm	185mm	160mm	95mm	200mm	55mm
		52.9lbs	10.236"	5.905"	7.28"	6.30"	3.74"	7.87"	2.16"
EC2800SS	Heel Shroud	35kg	270mm	200mm	250mm	197.5mm	150mm	200mm	50mm
		77.2lbs	10.63"	7.87"	9.84"	7.78"	5.91"	7.87"	1.97"
EC2870SS	Heel Shroud	107kg	213mm	116mm	1100mm	974mm	63mm	150mm	53mm
		235lbs	8.39"	4.56"	43.31"	38.35"	2.48"	5.90"	2.09"



Typical machine usage and conversion equivalent

Product Code	Description	Convert to	Machine usage
EC3515S	Heel Shroud (24kg)	ES6697-2 (21kg)	Excavators circa 100t and LHD R1700/R2900
EC2800SS	Heel Shroud (35kg)	157-1019 (32kg)	LHD R1700 / R2900
EC2870SS	Long HS (107kg)	SHS50X1100-LHD	LHD R1700 / R2900

Disclaimer: product information correct at time of publication, information may be modified without prior notice always follow the correct installation procedures whilst taking the necessary precautionary measures.

Material specifications

WF-0100: Abrasion Resistant Steel
 Tensile Strength: 1700 Mpa
 Yield Strength: 1320 Mpa
 Hardness: 470 - 520 BHN

Complementary products - Full Bucket protection

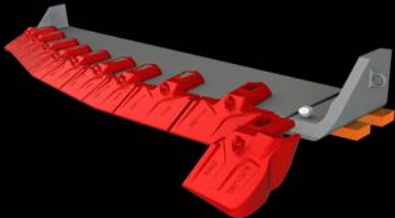

Shroud systems

We have a range of mechanical, weld-on and bolt-on underground shroud systems that can adapt to your machine and site needs.

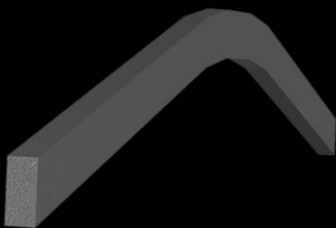

Wearstrips and profile bars

With onsite cutting facilities, we recommend that our customers use C4800 or C8000 - an advanced high resistant performance steel with better wear properties than conventional Q&T plate - for all profile bars and strips to protect their buckets and extend shroud wear-life.

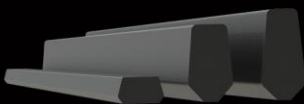

Grouser Bars

We stock a range of grouser bars to protect bucket cheeks and critical areas from wear that do not disrupt the in and outward flow of material.

Wearplate

Cut and rolled to your requirements, we can supply you with wear skins for your buckets manufactured from QT450 grade plate or similar.

Head office - Australia
Address 533 Abernethy Road,
Kewdale, Western Australia 6105
Tel +61 (0) 8 9353 6111
Fax +61 (0) 8 9353 6188
Email sales@wearforce.com.au

www.wearforce.com.au

Kalgoorlie Branch- Australia
Address 5 Hudson Place, West
Kalgoorlie, Western Australia, 6430
Tel +61 (0) 8 9022 8035
Fax +61 (0) 8 9022 8032
Email sales@wearforce.com.au

www.wearforce.com.au

North American Office
Address 359 New St,
Quakertown, PA 18951, USA
Tel +1 (215) 996 1770
Fax +1 (215) 822 1423
Email sales@wearforcena.com

www.wearforcena.com